

NxxH Series Current Sensor

The NxxH series is a current transducer which operates on the principle of magnetic compensation. It measures DC, AC or pulse currents and their combinations, with galvanic isolation techniques used to separate the primary and secondary circuits.



Features

- Non-contact measurement of high current
- Close-Loop measurement (compensated)
- Max. measuring range $\pm 212\text{A}$ (DC or AC peak)
- Nearly zero magnetic hysteresis
- Superior temperature stability and linearity
- High frequency bandwidth 100kHz
- RoHs compliance (Lead-Free)

Applications

- Home appliances
- AC variable speed drives and servo motor drives
- Static converters for DC motor drives
- Battery management systems
- Uninterruptible power supplies (UPS)
- Switched-mode power supplies (SMPS)
- Overcurrent protections
- Short circuit protections

Advantages

- Accurately measures AC, DC and pulse currents
- Fast response $< 0.5\mu\text{s}$
- High immunity from external interference
- Excellent current overload capacity

Standards

- EN 50178:1997
- IEC 60950-1:2006
- IEC 61010-1:2010

Absolute maximum ratings

Symbol	Parameter	Min.	Max.	Unit
$V_{DD\ max.}$	Maximum supply voltage (not destructive)	-15.75	15.75	V
I_{PM}	Maximum measuring current	-212	212	A
T_A	Ambient operating temperature	-40	85	°C
T_S	Storage temperature range	-40	100	°C
$V_{ESD-HBM}$	ESD sensitivity HBM (Human Body Model)		8	kV

Stresses above these ratings may cause permanent damage. Exposure to absolute maximum ratings for extended periods may degrade reliability.

Specifications ($T_A = 25^\circ\text{C}$, $V_{DD} = \pm 15.0\text{V}$)

Symbol	Parameter	n50H	n502H	n100H	n1002H	n125H	n1252H	n1502H	Unit
V_{DD}	Supply voltage	± 15							V
I_C	Current consumption @ $I_P=0$ without I_{OE}	<10							mA
I_{PN}	Current nominal measuring range	± 50	± 50	± 100	± 100	± 125	± 125	± 150	A
I_{PM}	Current maximum measuring range	± 90	± 150	± 150	± 180	± 200	± 200	± 212	A
K_n	Conversion ratio	1:1,000	1:2,000	1:1,000	1:2,000	1:1,000	1:2,000	1:2,000	
I_{SN}	Secondary nominal rms current	± 50	± 25	± 100	± 50	± 125	± 62.5	± 75	mA
R_S	Coil resistance @25 °C	< 30	< 100	< 30	< 100	< 30	< 100	< 100	Ω
R_M	Measuring resistance	60~120	70~140	30~70	60~120	30~50	50~90	30~78	Ω
T_{COT}	Temperature coefficient of I_{OUT} @-40°C ...85 °C	± 0.3 Typ./ ± 0.5 Max.	± 0.15 Typ./ ± 0.3 Max.	± 0.3 Typ./ ± 0.5 Max.	± 0.15 Typ./ ± 0.3 Max.	± 0.3 Typ./ ± 0.5 Max.	± 0.15 Typ./ ± 0.3 Max.	± 0.15 Typ./ ± 0.3 Max.	mA
ϵ_L	Non-linearity error @ $\pm I_{PN}$ without offset	<0.1	<0.1	<0.1	<0.1	<0.1	<0.1	<0.1	%/ I_{PN}
I_{OE}	Offset current @ $I_P=0$	± 0.2	± 0.15	± 0.2	± 0.15	± 0.2	± 0.15	± 0.15	mA
T_{RA}	Step response to 10% of I_{PN}	<0.3							μs
T_R	Step response to 90% of I_{PN}	<0.5							μs
BW	Frequency bandwidth (-3dB)	100							kHz
di/dt	di/dt accurately followed	50							A/ μs

Insulation characteristics

Symbol	Parameter	Value	Unit	Comment
V_0	Insulation voltage for isolation, 50Hz, 1 min	3000	V	
R_{ISO}	Isolation resistance @500VDC	>500	$m\Omega$	

General characteristics

Symbol	Parameter	Value	Unit	Comment
m-HSE	Housing material	V0		Flame retardant UL 94
m-CDT	Conductor material	H62		Busbar version
m-FC	Flux collector material	Permalloy		Superior magnetic permeability

Dimension (mm)

N100, N1002H, N125H, N1252H

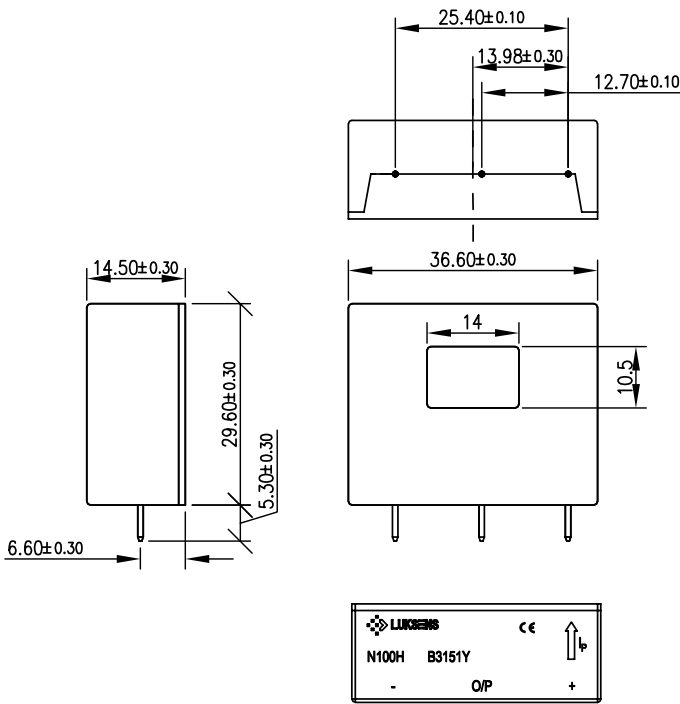

N50H, N502H, N1502H

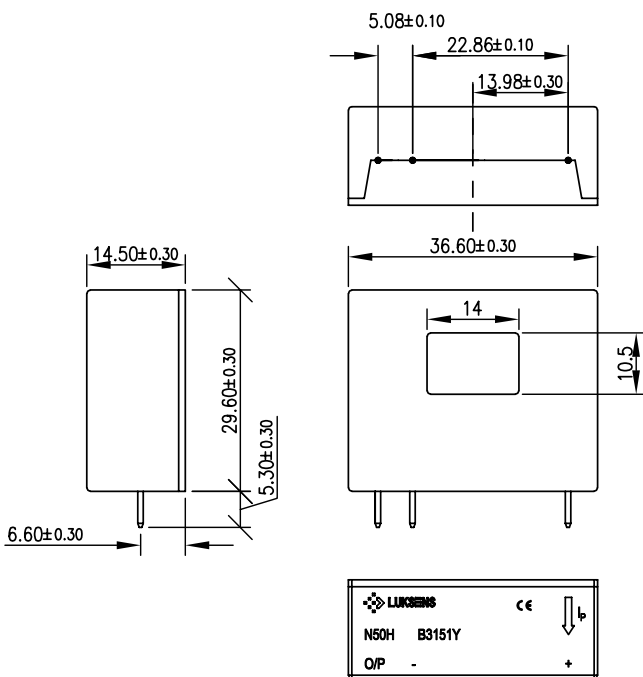

Connection diagram:

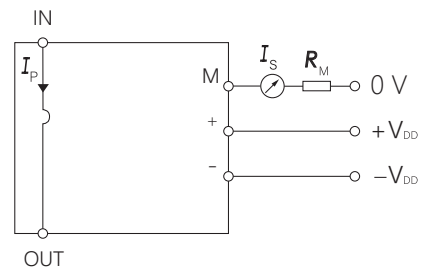

Name Guide Description

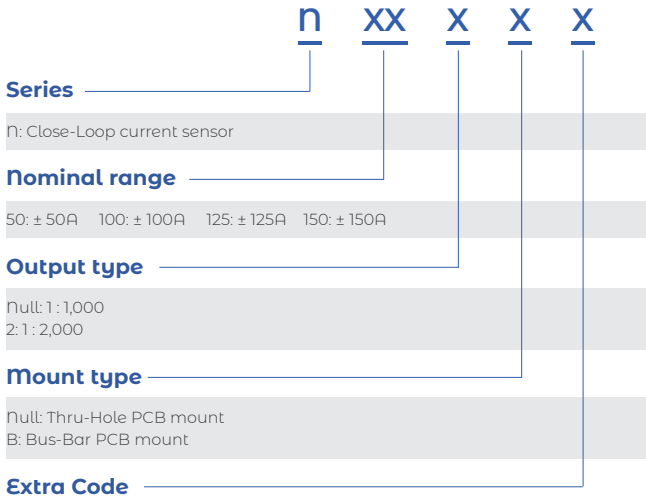

Notes

The content of this document is subject to revision without notice. Luksens shall have no liability for any error or damage of any kind resulting from the use of this document.

Safety and Environment



The product is to be installed by manufacturer trained personnel or competent person trained in accordance with manufacturer installation instructions.

With respect to applicable standards IEC 61010-1/ EN 61010-1 *safety requirements for electrical equipment for measurement, control and laboratory use part 1 general requirements*, the product should be used in limited energy secondary circuits.



Risk of electrical shock

Certain parts of the module can carry hazardous voltage during the operation process of the product because hazardous live voltage of primary conductor, power supply occurs, injury and/or serious damage will be caused if this warning is ignored.

Conducting parts must be inaccessible after installation of the product. Additional protection including shield or protective housing could be used according to IEC 60664 Insulation coordination for equipment within low-voltage supply systems.

Disconnection of the main supply will protect against possible injury and serious damage.



ESD protection

Damage from an ESD event will occur if the personnel is not well grounded when handling.

Important notice

Luksens reserves the right to change the specifications, including all statements and data appearing in Luksens' catalogues, data sheets and advertisements, without notice. Luksens will publish the modified specifications on its website. If such changes to specifications are made, Luksens shall have no obligation to provide the change on Products previously purchased. The information included herein is believed to be accurate and reliable. However, since additional design, measure, production, quality control take effect in the end product, therefore Luksens shall have no liability for any potential hazards, damages, injuries or loss of life resulting from the end product. Luksens products are not to be used in any equipment or system, including but not limited to life support equipment or systems, where failure of Luksens products may cause bodily harm.