

LF01 Series Fluxgate Current Sensor

The LF01 series fluxgate current sensor incorporates dynamic fluxgate detection technology. Its design is simple and practical, with the ability to inhibit high temperature drift. Fluxgate technology makes use of the phenomenon of magnetic core saturation to modulate the measured magnetic field, transforming it into an electric field and thus, completing the magnetic field measurement process.

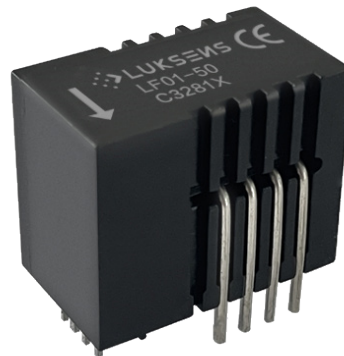

Features

- Non-contact measurement of high current
- Fluxgate technology without hall element
- Output voltage proportional to carried current
- Max. measuring range $\pm 150\text{A}$ (DC or AC peak)
- High frequency bandwidth 300kHz
- Compact size for PCB mount
- RoHs compliance (Lead-Free)

Applications

- Solar inverters
- Servo motor drives
- Uninterruptible power supplies
- Battery management systems
- Welding applications

Advantages

- Accurately measures AC, DC and pulse currents
- Rapid response, minimal noise output
- Superior temperature stability and linearity
- No insertion losses
- High immunity from external interference
- Nearly zero offset voltage
- High ESD sensitivity (Human Body Model) 4kV

Standards

- EN 50178: 1997
- IEC 60950-1:2006
- IEC 61010-1:2010
- IEC 62109-1: 2010

Absolute maximum ratings

Symbol	Parameter	Min.	Max.	Unit
$V_{DD\ max.}$	Maximum supply voltage (not destructive)		7	V
T_{PC}	Primary conductor temperature		110	°C
T_A	Ambient operating temperature	-40	105	°C
T_S	Storage temperature range	-40	105	°C
$V_{ESD-HBM}$	ESD sensitivity HBM (Human Body Model)		4	kV

Stresses above these ratings may cause permanent damage. Exposure to absolute maximum ratings for extended periods may degrade reliability.

Specifications ($T_A = 25^\circ\text{C}$, $V_{DD} = 5.0\text{V}$)

Symbol	Parameter	Test condition	Min.	Typ.	Max.	Unit
V_{DD}	Supply voltage		4.75	5	5.25	V
I_C	Current consumption ($I_P=0\text{A}$ without load)	LF01-06		25		mA
		LF01-15		30		
		LF01-25		35		
		LF01-50		55		
I_{PN}	Current nominal measuring range	LF01-06	-20	± 06	20	A
		LF01-15	-51	± 15	51	
		LF01-25	-85	± 25	85	
		LF01-50	-150	± 50	150	
n_p	Number of primary turns		1, 2, 3, 4			
n_s	Number of secondary turns	LF01-06	1,816			
		LF01-15	1,737			
		LF01-25	1,764			
		LF01-50	1,600			
V_{REF1}	Internal reference voltage	$I_P=0\text{A}$	2.495	2.5	2.505	V
V_{REF2}	External reference voltage		0		4	V
V_{OUT}	Output voltage range		0.375		4.625	V
V_0	Zero current output voltage	$I_P=0\text{A}$	V_{REF1} or V_{REF2} ^{*1}			V

*1 V_0 can work in internal reference voltage (V_{REF1}) or external reference voltage (V_{REF2}) mode.

Specifications ($T_A = 25^\circ\text{C}$, $V_{DD} = 5.0\text{V}$)

Symbol	Parameter	Test condition	Min.	Typ.	Max.	Unit
V_{OE}	Offset voltage $V_{OE} = V_{OUT} (@I_p = 0A) - V_{REF1 \text{ or } REF2}$	LF01-06	-5.3		5.3	mV
		LF01-15	-2.21		2.21	
		LF01-25	-1.35		1.35	
		LF01-50	-0.725		0.725	
I_{OE}	Offset current referred to primary without magnetic hysteresis	LF01-06	-51		51	mA
		LF01-15	-53		53	
		LF01-25	-54		54	
		LF01-50	-58		58	
T_{CVREF1}	Temperature coefficient of V_{REF1}		-50	± 5	50	ppm/ $^\circ\text{C}$
T_{CVO}	Temperature coefficient of V_o @ $I_p = 0A$ $T_A = -40^\circ\text{C} \dots 105^\circ\text{C}$, $V_o = 2.5V$	LF01-06	-14	± 6	14	ppm/ $^\circ\text{C}$
		LF01-15	-6	± 2.3	6	
		LF01-25	-4	± 1.4	4	
		LF01-50	-3	± 0.7	3	
G	Nominal sensitivity ($625\text{mV} / I_{pN}$)	LF01-06		104.2		mV/A
		LF01-15		41.67		
		LF01-25		25		
		LF01-50		12.5		
ϵ_G	Sensitivity error	$\pm I_{pN}$	-0.7		0.7	$\% / I_{pN}$
T_{CG}	Temperature coefficient of G	$T_A = -40^\circ\text{C} \dots 105^\circ\text{C}$	-40		40	ppm/ $^\circ\text{C}$
ϵ_L	Non-linearity error	$\pm I_{pN}$ without offset	-0.1		0.1	$\% / I_{pN}$
I_{om}	Magnetic offset current	After $10 \cdot I_p$ overload	-0.1		0.1	A
V_{NP-P}	Peak-Peak output noise $R_L = 1k\Omega$	LF01-06		40	160	mV
		LF01-15		15	60	
		LF01-25		10	40	
		LF01-50		5	20	
T_{RA}	Step response to 10% of I_{pN} , $di/dt = 18A / \mu s$	LF01-06		0.3	1	μs
	Step response to 10% of I_{pN} , $di/dt = 44A / \mu s$	LF01-15		0.3	1	
	Step response to 10% of I_{pN} , $di/dt = 68A / \mu s$	LF01-25		0.3	1	
	Step response to 10% of I_{pN} , $di/dt = 100A / \mu s$	LF01-50		0.3	1	

Specifications ($T_A = 25^\circ\text{C}$, $V_{DD} = 5.0\text{V}$)

Symbol	Parameter	Test condition	Min.	Typ.	Max.	Unit
T_R	Step response to 90% of I_{pr} , $di/dt = 18\text{A}/\mu\text{s}$	LF01-06		0.5	1	μs
	Step response to 90% of I_{pr} , $di/dt = 44\text{A}/\mu\text{s}$	LF01-15		0.5	1	
	Step response to 90% of I_{pr} , $di/dt = 68\text{A}/\mu\text{s}$	LF01-25		0.5	1	
	Step response to 90% of I_{pr} , $di/dt = 100\text{A}/\mu\text{s}$	LF01-50		0.5	1	
BW	Frequency bandwidth(-1dB)		200			kHz
BW	Frequency bandwidth(-3dB)		300			kHz

Insulation characteristics

Symbol	Parameter	Value	Unit	Comment
V_o	Insulation voltage for isolation, 50Hz, 1 min	4300	V	
R_{iso}	Isolation resistance @ DC 500V	>500	$\text{M}\Omega$	
D-CLE	Clearance	8.3	mm	Shortest distance through air
D-CRD	Creepage distance	8.3	mm	Shortest path along sensor body

General characteristics

Symbol	Parameter	Value	Unit	Comment
m-HSE	Housing material	V0		Flame retardant UL 94
m-CDT	Conductor material	H62		
m	Mass	12	grams	

Current measurement range versus external reference voltage

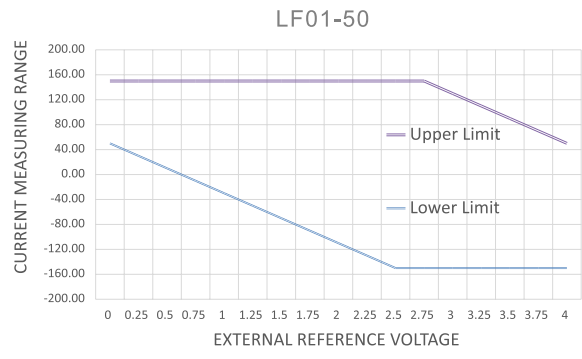
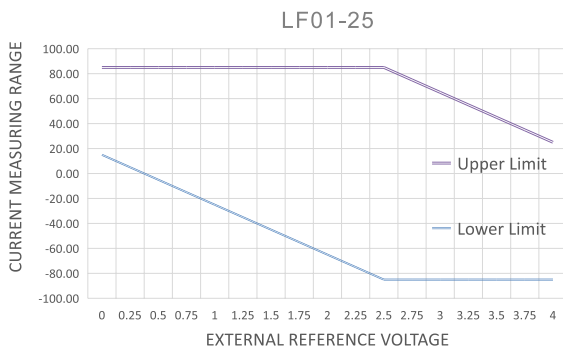
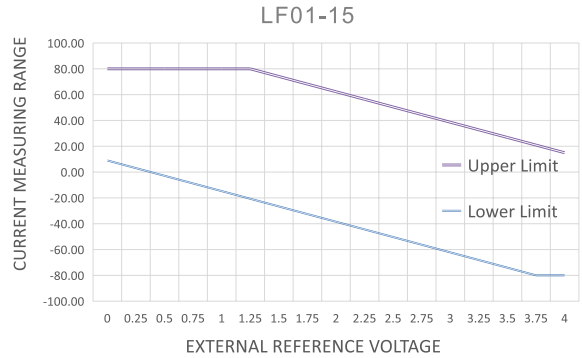
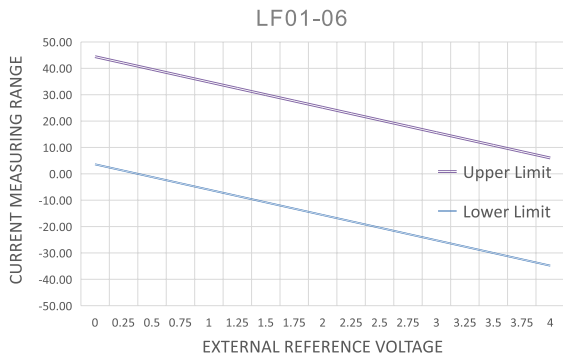

Max. DC primary current versus ambient temperature

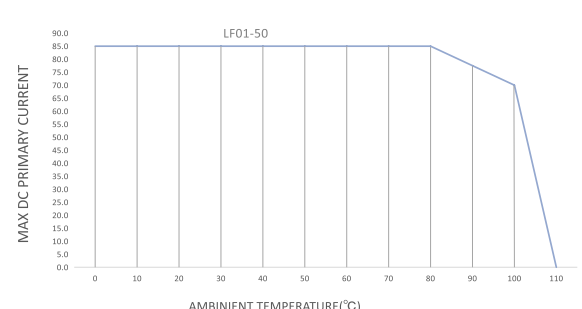
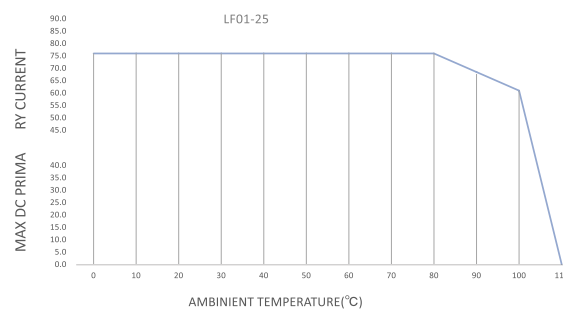
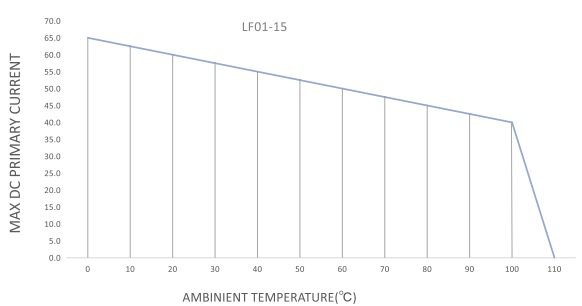
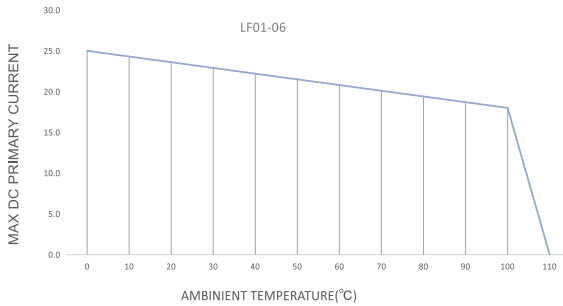

PCB footprint (mm, general tolerance $\pm 0.05\text{mm}$)

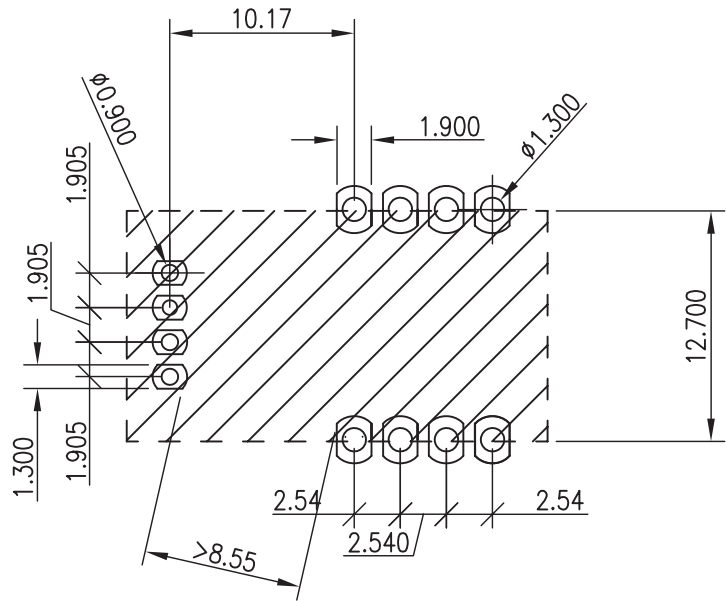

Note:

Maximum soldering temperature 260°C 10s

Maximum PCB thickness 2.4mm

Dimension (mm)

Pin	Symbol
1	—
2	Input
3	Input
4	Input
5	Input
6	Output
7	Output
8	Output
9	Output
10	—
11	V_{REF}^{*1}
12	V_0
13	GND
14	V_{DD}

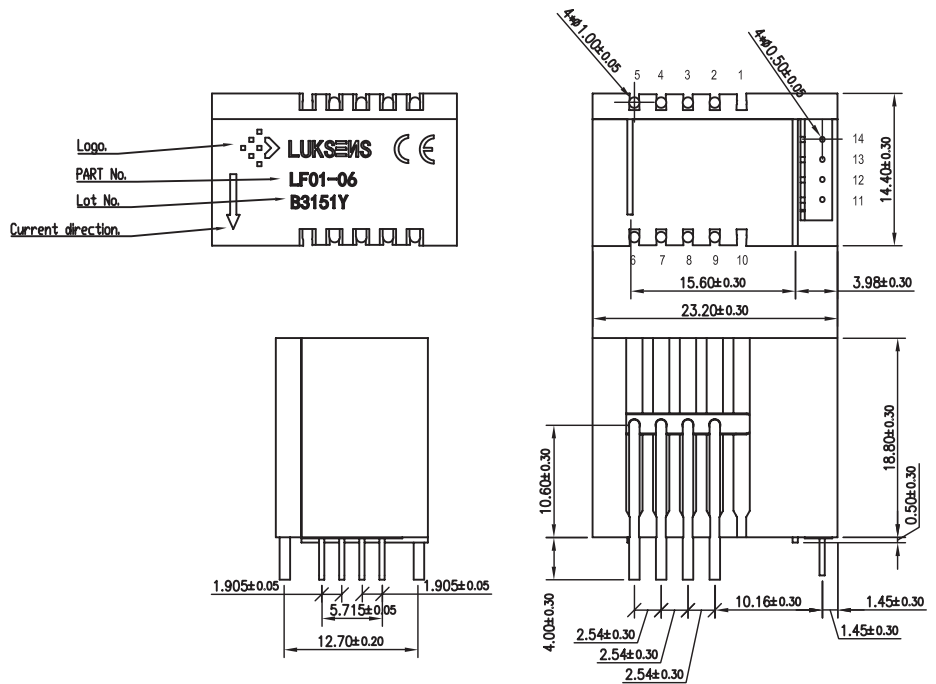

*1 V_{REF} can be used in internal reference or external reference voltage mode

Name Guide Description

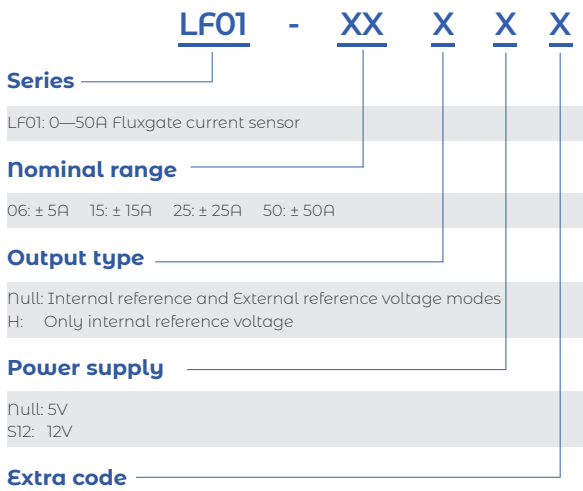

Notes

The content of this document is subject to revision without notice. Luksens shall have no liability for any error or damage of any kind resulting from the use of this document.

Safety and Environment



The product is to be installed by manufacturer trained personnel or competent person trained in accordance with manufacturer installation instructions.

With respect to applicable standards IEC 61010-1/ EN 61010-1 *safety requirements for electrical equipment for measurement, control and laboratory use part 1 general requirements*, the product should be used in limited energy secondary circuits.



Risk of electrical shock

Certain parts of the module can carry hazardous voltage during the operation process of the product because hazardous live voltage of primary conductor, power supply occurs, injury and/or serious damage will be caused if this warning is ignored.

Conducting parts must be inaccessible after installation of the product. Additional protection including shield or protective housing could be used according to IEC 60664 Insulation coordination for equipment within low-voltage supply systems.

Disconnection of the main supply will protect against possible injury and serious damage.



ESD protection

Damage from an ESD event will occur if the personnel is not well grounded when handling.

Important notice

Luksens reserves the right to change the specifications, including all statements and data appearing in Luksens' catalogues, data sheets and advertisements, without notice. Luksens will publish the modified specifications on its website. If such changes to specifications are made, Luksens shall have no obligation to provide the change on Products previously purchased. The information included herein is believed to be accurate and reliable. However, since additional design, measure, production, quality control take effect in the end product, therefore Luksens shall have no liability for any potential hazards, damages, injuries or loss of life resulting from the end product. Luksens products are not to be used in any equipment or system, including but not limited to life support equipment or systems, where failure of Luksens products may cause bodily harm.