

K03 Series Current Sensor

The K03 series is an Open-Loop current sensor based on the Hall effect. It provides electronic measurement of DC, AC or pulse currents at same time, and their combinations with galvanic between the primary (high current) and secondary circuits.



Features

- Non-contact measurement of high current
- Output voltage proportional to carried current
- Max. measuring range $\pm 1000\text{A}$ (DC or AC peak)
- RoHs compliance (Lead-Free)

Applications

- Frequency converters
- Servo motor drives
- Battery management systems
- Welding applications

Advantages

- Design for wide current range measurement
- High immunity from external interference
- High ESD sensitivity (Human Body Model) 8kV

Standards

- EN 50178:1997
- IEC 61010-1:2010
- IEC 61800-5-1:2020

Absolute maximum ratings

Symbol	Parameter	Min.	Max.	Unit
$V_{DD\ max.}$	Maximum supply voltage (not destructive)	-15.7	15.7	V
I_{PM}	Maximum measuring current	-1000	1000	A
T_{PC}	Primary conductor temperature		110	°C
T_A	Ambient operating temperature	-10	80	°C
T_S	Storage temperature range	-25	85	°C
$V_{ESD-HBM}$	ESD sensitivity HBM (Human Body Model)		8	kV

Stresses above these ratings may cause permanent damage. Exposure to absolute maximum ratings for extended periods may degrade reliability.

Specifications ($T_A = 25^\circ\text{C}$, $V_{DD} = \pm 15.0\text{V}$)

Symbol	Parameter	Test condition	Min.	Typ.	Max.	Unit
V_{DD}	Supply voltage			±15		V
I_C	Current consumption	$I_p=0\text{A}$ without load		15	20	mA
I_{PN}	Current nominal measuring range	K03D050D15	-150	±50	150	A
		K03D100D15	-300	±100	300	
		K03D200D15	-600	±200	600	
		K03D300D15	-900	±300	900	
		K03D400D15	-1000	±400	1000	
		K03D500D15	-1000	±500	1000	
		K03D600D15	-1000	±600	1000	
		K03D700D15	-1000	±700	1000	
		K03D800D15	-1000	±800	1000	
V_{OUT}	Output voltage	$\pm I_{PN}$		±4		V
V_{OE}	Offset voltage	$I_p=0\text{A}$	-40		40	mV
R_{OUT}	Output internal resistance			100		Ω
R_L	Output load resistance	V_{OUT} to GND		>1		kΩ
ϵ_L	Non-linearity error	$\pm I_{PN}$ without offset		<±1		%/ I_{PN}

Specifications ($T_A = 25^\circ\text{C}$, $V_{DD} = \pm 15.0\text{V}$)

Symbol	Parameter	Test condition	Min.	Typ.	Max.	Unit
V_{om}	Magnetic offset voltage	$I_p = 0\text{A} \rightarrow I_{pn} \rightarrow 0\text{A}$		± 20		mV
T_{cvoe}	Temperature coefficient of V_{oe}	K03D050D15	-2		2	mV/K
		K03D100...800D15	-1		1	mV/K
T_{cvout}	Temperature coefficient of V_{out}	$T_A = -10^\circ\text{C} \dots 80^\circ\text{C}$ (except T_{cvoe})	-0.1		0.1	%/°C
T_R	Step response to 90% of I_{pn}			3	5	μs
BW	Frequency bandwidth(-3dB)			50		kHz

Insulation characteristics

Symbol	Parameter	Value	Unit	Comment
V_D	Insulation voltage for isolation, 50Hz, 1 min	3600	V	
R_{iso}	Isolation resistance @500VDC	>500	$M\Omega$	
D-CLE	Clearance	6.3	mm	Shortest distance through air
D-CRD	Creepage distance	7.2	mm	Shortest path along sensor body

General characteristics

Symbol	Parameter	Value	Unit	Comment
m-HSE	Housing material	V0		Flame retardant UL 94
m-FC	Flux collector material	Oriented silicon steel		Superior magnetic permeability
m	Mass	50	grams	

Dimension (mm)

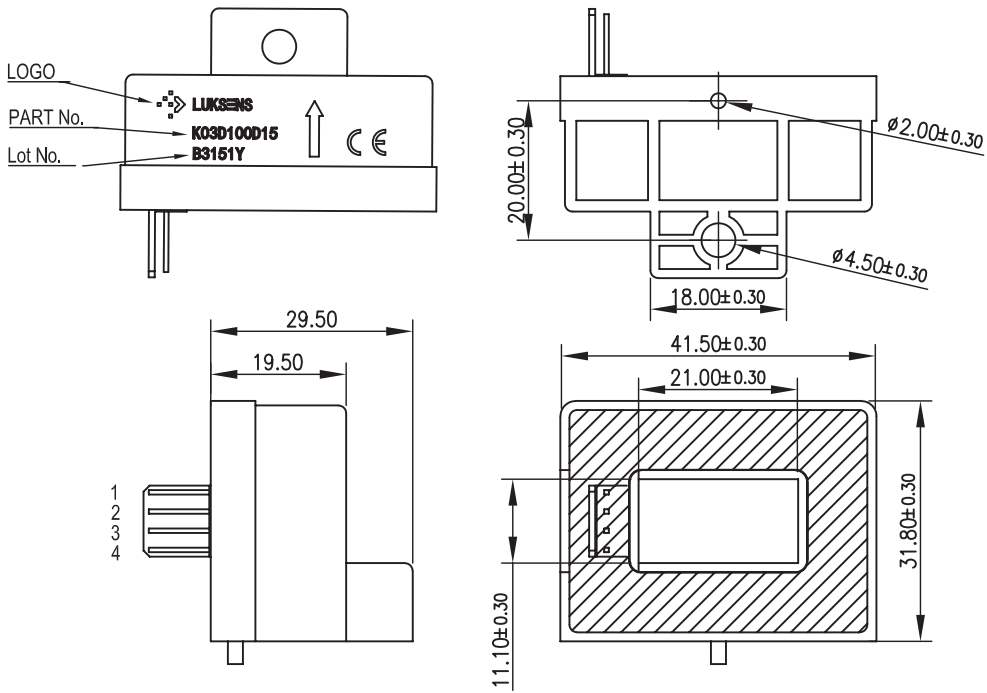

Pin	Symbol
1	+V _{DD}
2	-V _{DD}
3	V _{OUT}
4	GND

Name Guide Description

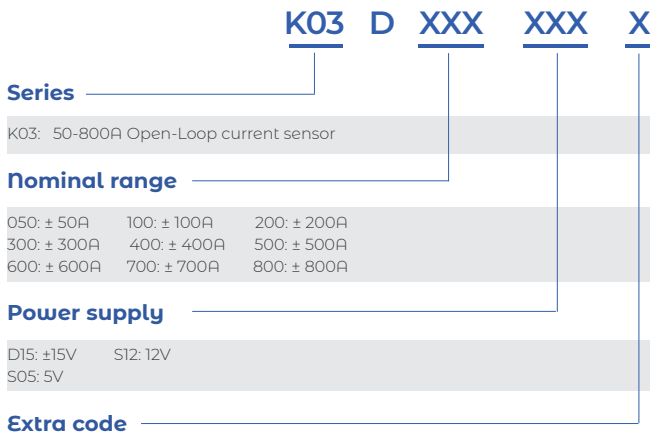

Notes

The content of this document is subject to revision without notice. Luksens shall have no liability for any error or damage of any kind resulting from the use of this document.

Safety and Environment



The product is to be installed by manufacturer trained personnel or competent person trained in accordance with manufacturer installation instructions.

With respect to applicable standards IEC 61010-1/ EN 61010-1 *safety requirements for electrical equipment for measurement, control and laboratory use part 1 general requirements*, the product should be used in limited energy secondary circuits.



Risk of electrical shock

Certain parts of the module can carry hazardous voltage during the operation process of the product because hazardous live voltage of primary conductor, power supply occurs, injury and/or serious damage will be caused if this warning is ignored.

Conducting parts must be inaccessible after installation of the product. Additional protection including shield or protective housing could be used according to IEC 60664 Insulation coordination for equipment within low-voltage supply systems.

Disconnection of the main supply will protect against possible injury and serious damage.



ESD protection

Damage from an ESD event will occur if the personnel is not well grounded when handling.

Important notice

Luksens reserves the right to change the specifications, including all statements and data appearing in Luksens' catalogues, data sheets and advertisements, without notice. Luksens will publish the modified specifications on its website. If such changes to specifications are made, Luksens shall have no obligation to provide the change on Products previously purchased. The information included herein is believed to be accurate and reliable. However, since additional design, measure, production, quality control take effect in the end product, therefore Luksens shall have no liability for any potential hazards, damages, injuries or loss of life resulting from the end product. Luksens products are not to be used in any equipment or system, including but not limited to life support equipment or systems, where failure of Luksens products may cause bodily harm.