

AC3PXXX-07/P3 Series Current Sensor

The AC3PXXX-07/P3 current sensor series is a tri-phase transducer, specially designed for low voltage, high current measurement in automotive applications. It provides solutions with faster speed and higher performance-price ratio for DC, AC or pulse currents measurement, with galvanic isolation techniques used to separate the primary and secondary circuits.



Features

- Perfect fit to "HybridPACK™" drive Infineon
- All in one tri-phase transducer (optional with 2 phase and 3 phase measurement)
- Unipolar 5V DC power supply (3.3V available)
- Analog signal output

Advantages

- High accuracy sensor in automotive applications
- Fast response 4μs
- No insertion losses
- Small and thin size
- High performance-price ratio
- High frequency bandwidth

Automotive applications

- Starter generators
- Inverters
- HEV applications
- EV applications
- DC / DC converter

Standards

- IEC 60068-2-1:2007
- IEC 60068-2-2:2007
- IEC 60068-2-14:2009
- IEC 60068-2-27:2008
- IEC 60068-2-78 :2001
- ISO 11452-1

Absolute maximum ratings

Symbol	Parameter	Rating	Unit
$V_{DD\ max.}$	Maximum supply voltage (not destructive)	8	V
I_C	Current consumption	18	mA
I_{OUT}	Output current	± 40	mA
T_A	Ambient operating temperature	-40 to 125	$^{\circ}C$
T_S	Storage temperature range	-40 to 125	$^{\circ}C$
$V_{ESD-HBM}$	ESD sensitivity HBM (Human Body Model)	4	KV
V_0	Insulation voltage for isolation	2.5	KV
D-CRD	Creepage distance	13.6	mm
D-CLE	Clearance	12	mm
CTI	CTI	PLC3	--

Stresses above these ratings may cause permanent damage. Exposure to absolute maximum ratings for extended periods may degrade reliability.

Specifications ($T_A = 25^{\circ}C$, $V_{DD} = 5.0V$)

Symbol	Parameter	Test condition	Min.	Typ.	Max.	Unit
V_{DD}	Supply voltage		4.75	5	5.25	V
I_{PN}	Current nominal measuring range	AC3P800-07/P3	-800		800	A
		AC3P900-07/P3	-900		900	
		AC3P1000-07/P3	-1000		1000	
V_{OUT}	Output voltage	$\pm I_{PN}$	$V_{OUT} = V_{DD} / 2 + (2 \times I_P / I_{PN})$			V
G	Nominal sensitivity (customized available)	AC3P800-07/P3	2.5			mV/A
		AC3P900-07/P3	2.22			
		AC3P1000-07/P3	2			

Specifications ($T_A = 25^\circ\text{C}$, $V_{DD} = 5.0\text{V}$)

Symbol	Parameter	Test condition	Min.	Typ.	Max.	Unit
R_L	Output load resistance	V_{OUT} to GND	5			$k\Omega$
C_L	Output load capacitance	V_{OUT} to GND			10	nF
V_0	Zero current output	$I_p=0A$ @ $T_A=25^\circ\text{C}$		$V_{DD}/2$		V
ϵ_G	Sensitivity error	$V_{DD}=5V$ @ $T_A=25^\circ\text{C}$	-1	± 0.5	1	%
V_{OE}	Offset voltage	$I_p=0A$ @ $T_A=25^\circ\text{C}$	-10	± 5	10	mV
V_{Om}	Magnetic offset voltage	$I_p=0A$ @ $T_A=25^\circ\text{C}$, after excursion of I_{pN}		± 2		mV
T_{CVOE}	Temperature coefficient of V_{OE}	$T_A=-40^\circ\text{C} \dots 125^\circ\text{C}$	-0.3	± 0.1	0.3	mV/K
T_{CVOUT}	Temperature coefficient of V_{OUT}	$T_A=-40^\circ\text{C} \dots 125^\circ\text{C}$	-0.5	± 0.3	0.5	mV/K
ϵ_L	Non-linearity error	$\pm I_{pN}$ without offset	-1		1	%/ I_{pN}
BW	Frequency bandwidth (-3dB)			120		kHz
T_R	Step response to 90% I_{pN}	(Design target)		4		μs
$R_{PRIMARY}$	Primary conductor resistance	$T_A=25^\circ\text{C}$		1		$m\Omega$

General characteristics

Symbol	Parameter	Value	Unit	Comment
m-HSE	Housing material	PBT		Flame retardant UL 94
m-FC	Flux collector material	FeSi wound core		Superior magnetic permeability

Dimension (mm)

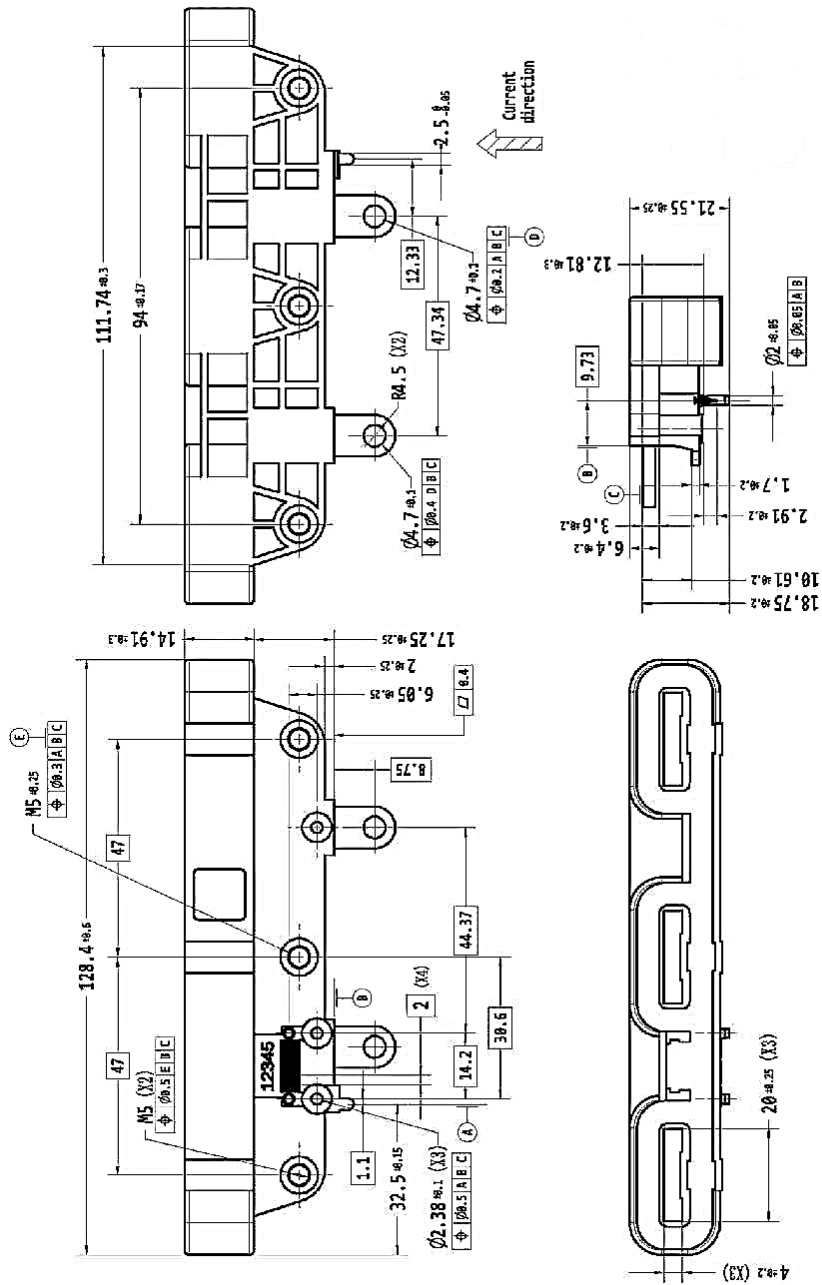

Pin	Symbol
1	V _{DD}
2	GND
3	V _{OUT 1}
4	V _{OUT 2}
5	V _{OUT 3}

Name Guide Description

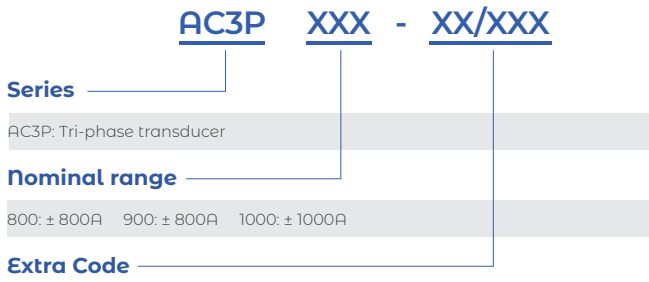

Notes

The content of this document is subject to revision without notice. Luksens shall have no liability for any error or damage of any kind resulting from the use of this document.

Safety and Environment



The product is to be installed by manufacturer trained personnel or competent person trained in accordance with manufacturer installation instructions.

With respect to applicable standards IEC 61010-1/ EN 61010-1 *safety requirements for electrical equipment for measurement, control and laboratory use part 1 general requirements*, the product should be used in limited energy secondary circuits.



Risk of electrical shock

Certain parts of the module can carry hazardous voltage during the operation process of the product because hazardous live voltage of primary conductor, power supply occurs, injury and/or serious damage will be caused if this warning is ignored.

Conducting parts must be inaccessible after installation of the product. Additional protection including shield or protective housing could be used according to IEC 60664 Insulation coordination for equipment within low-voltage supply systems.

Disconnection of the main supply will protect against possible injury and serious damage.



ESD protection

Damage from an ESD event will occur if the personnel is not well grounded when handling.

Important notice

Luksens reserves the right to change the specifications, including all statements and data appearing in Luksens' catalogues, data sheets and advertisements, without notice. Luksens will publish the modified specifications on its website. If such changes to specifications are made, Luksens shall have no obligation to provide the change on Products previously purchased. The information included herein is believed to be accurate and reliable. However, since additional design, measure, production, quality control take effect in the end product, therefore Luksens shall have no liability for any potential hazards, damages, injuries or loss of life resulting from the end product. Luksens products are not to be used in any equipment or system, including but not limited to life support equipment or systems, where failure of Luksens products may cause bodily harm.